



BTI **BHAVYA TECH INTERNATIONAL**
Address- R-31/B, East Vinod Nagar Delhi-110091
e-mail- bhavya.tech.int@gmail.com. Mob-954060035. 9990906248

BHAVYA TECH INTERNATIONAL

Office: PLOT NO:-42,1ST FLOOR, HASANPUR VILLAGE I P EXTENTION DELHI 110092
Email: bhavya.tech.int@gmail.com, Mobile:9540600035,9990906248
Corresponding Address: R-31/B, East Vinod Nagar, Delhi-110091

.....
GST NO: 07BLZPS1772C1ZL

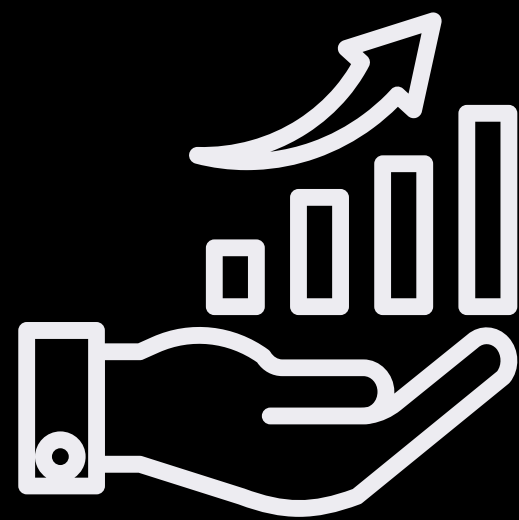

CONTENTS

- ABOUT US
- GOALS AND OBJECTIVES
- CONCEPT IN BUSINESS
- OUR PRODUCT
- DESIGNS
- OUR SERVICES
- OUR TEAM

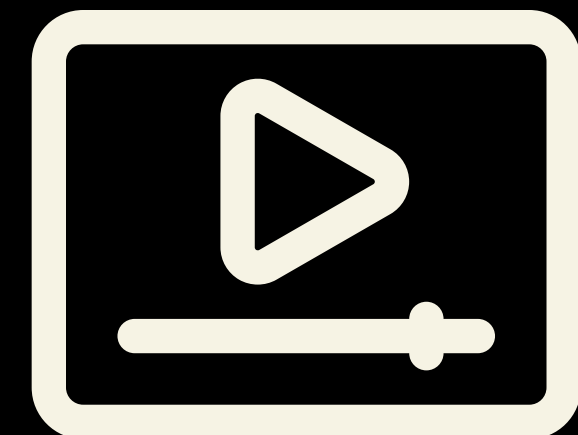
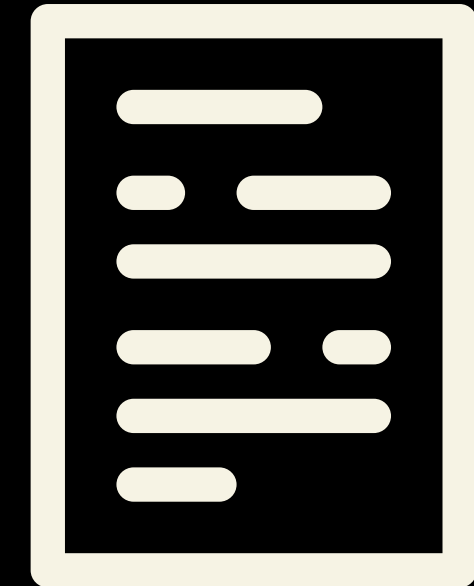
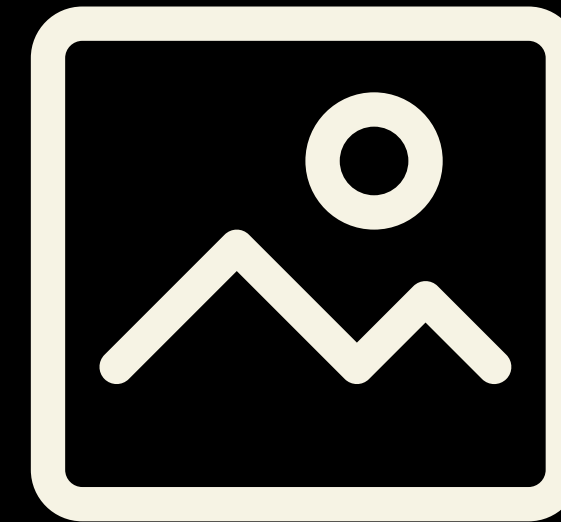

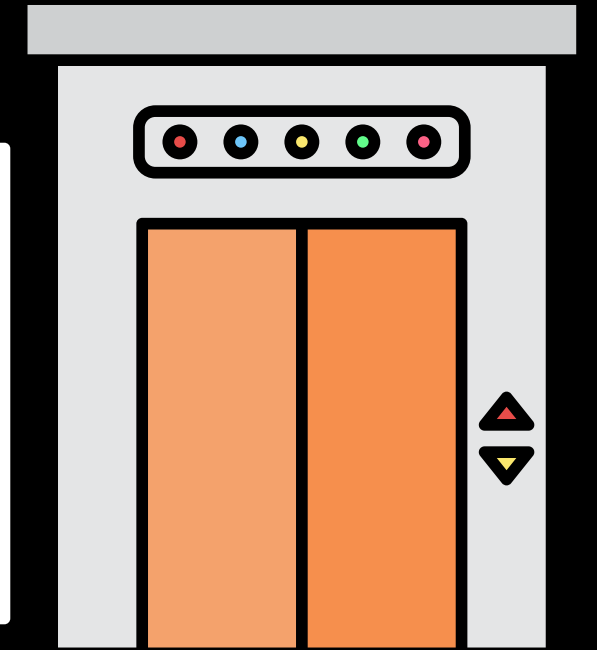
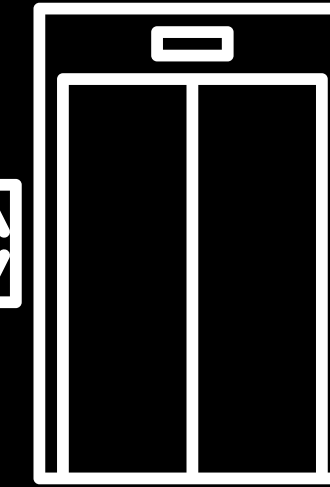
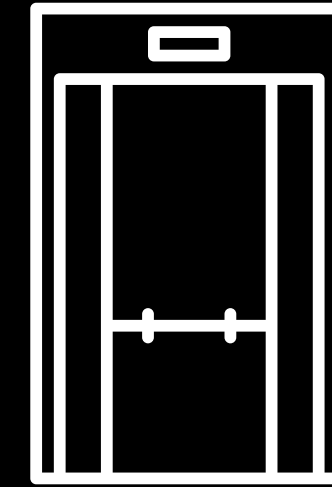

K/A Dear sir / Madam

ABOUT US : Bhavya Tech International is a Concern Started in 2014, which is exclusively dealing in Lift Hydraulic/ Goods hyd home lift/Car lift/Traction Passenger/ Goods & all material handling equipment's and have established a name in the market for the quality of products and excellent after-sale service.

The company do not depend on batch testing but take trials and tests of each and every unit on a safe working load as well as overload. As result, there is hardly any complaint from the users.

We have given a small introduction.

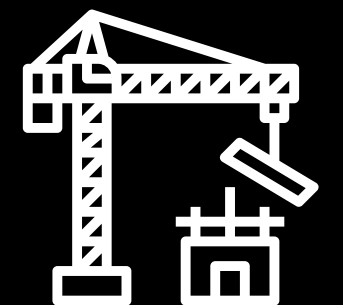



Bhavya Tech International, specializes in the modernization , Sale and maintenance of all types lifts ,Traction, Machine Room Less (MRL), Hydraulic, Counter wait lifts, rack pinion drive lifts ,Stair chair lift, Hydraulic wall Mounted Stacker (Goods/Passenger), Electronic wire Rope , Chain hoists , Hydraulic Stacker ,pallet Truck , Hand trolley ,Drum, Roll, warp beam pallet & box Handling Equipment and use for construction Machinery .

Bhavya Tech International offers the customer unparalleled levels of Sales & service quality and excellence. We are a progressive company reflecting the future of the Lift, MHE, Rack, Construction equipment's service & maintenance.



The main activity is the Sale & Service installation, maintenance, and modernization of elevators, car parking systems Material Handling , BMU, Storage and construction equipment.



Our extensive inventory of new and used different categories of lifts can fulfil any customer requirement. Industrial batteries and chargers are available both new and used for all types of equipment. Our experienced people are able to help you design all kinds of requirements.

We also repair and supply parts for all make and models of industrial material handling equipment. Our Organization service technicians are authorized to perform mandatory Annual Inspections on your aerial

GOALS AND OBJECTIVES

Deliver Superior Elevator Solutions

BHAVYA TECH INTERNATIONAL aims to design, manufacture, and install state-of-the-art elevators that meet the diverse needs of our clients. We strive to provide cutting-edge technology, energy efficient systems, and advanced safety features to ensure optimal performance and user satisfaction

Ensure Customer Satisfaction

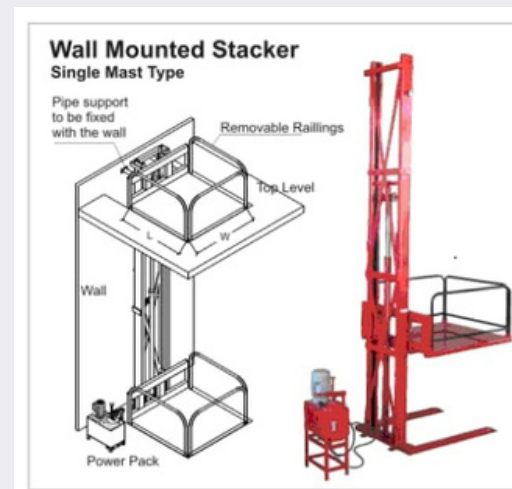

BHAVYA TECH INTERNATIONAL is committed to exceeding customer expectations by delivering superior service throughout the entire elevator lifecycle

Promote Safety and Accessibility.

Safety is paramount in the elevator industry, and BTI is dedicated to designing and implementing elevators that adhere to the highest safety standards.

CONCEPT IN BUSINESS

BTI seeks to be a leader in the elevator industry, providing exceptional solutions, outstanding customer service, and contributing to a safer, more accessible, and sustainable built environment.



OUR PRODUCT

Hydraulic Lifts

Hydraulic home lift

Hydraulic wheelchair lift

Hydraulic structure lift

Hydraulic out door lift



WHEEL CHAIR LIFT

CURVE STAIR LIFT

STAIR CHAIR LIFT

VACUUM LIFT

VACUUM HYDRAULIC LIFT



GEAR MACHINE LIFT

MRL LIFT

HYDRAULIC GOODS LIFT

DRUM WEIGHTIER LIFT

DRUM GOODS LIFT



HYDRAULIC LIFTS

Hydraulic lifts are a type of elevator that operate using hydraulic fluid, typically oil, to generate power and lift the elevator car

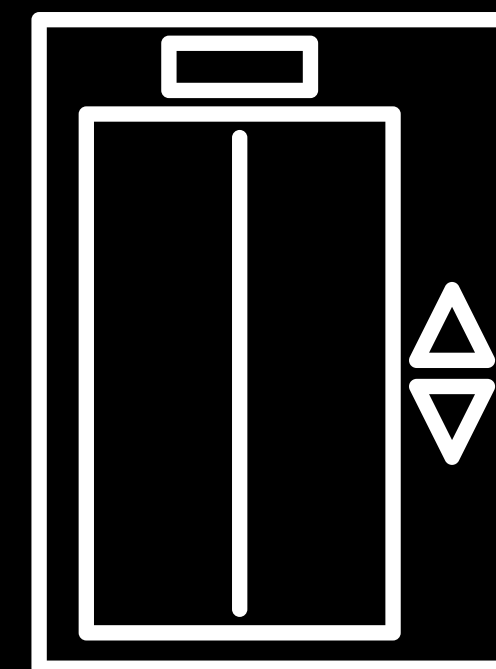
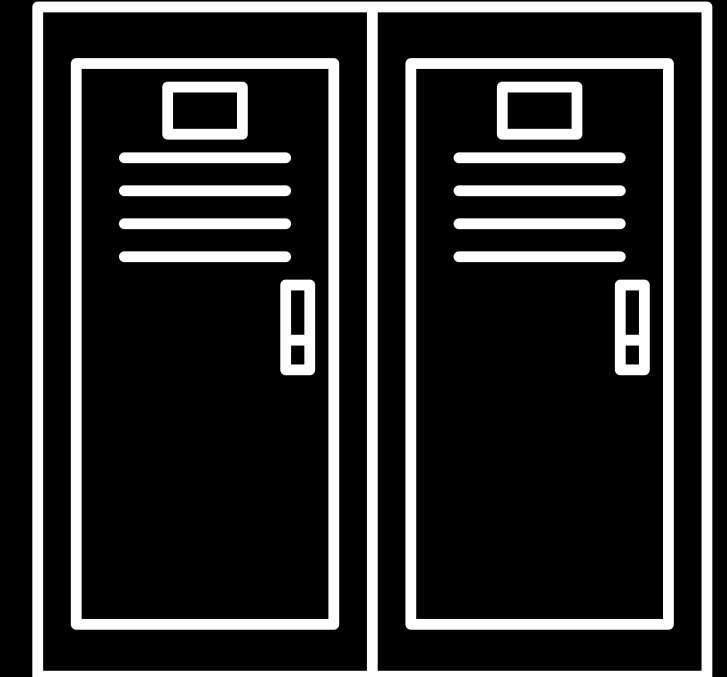
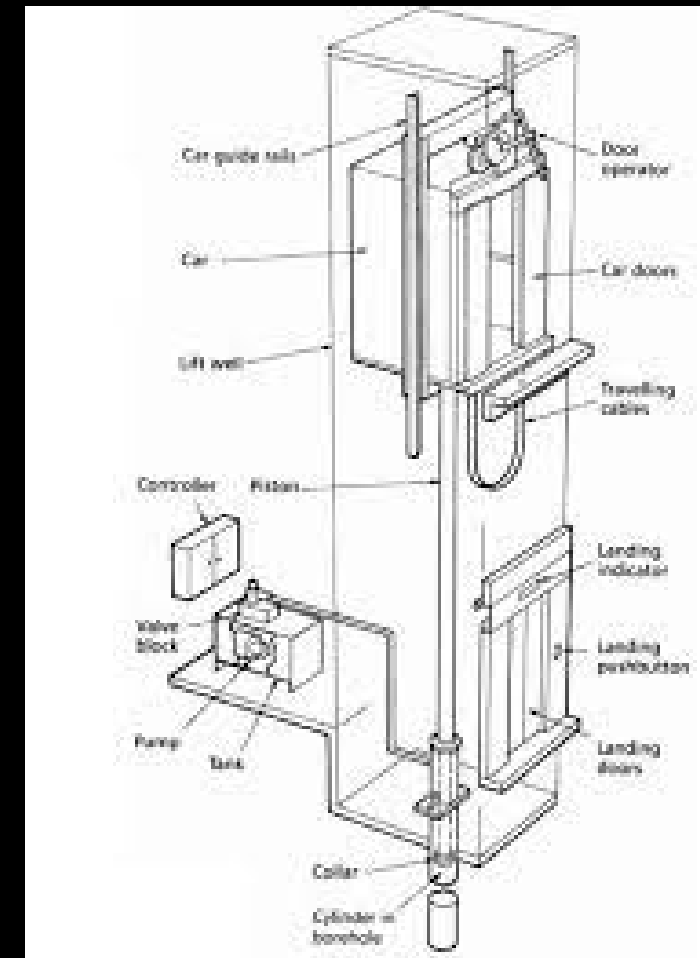

BENEFITS OF HYDRAULIC LIFTS

Versatility: Hydraulic lifts can be installed in a wide range of buildings, including low to mid-rise residential, commercial, and industrial structures. They are suitable for both indoor and outdoor installations.

Safety Features: Hydraulic lifts incorporate various safety features to ensure the well-being of passengers. These features may include emergency stop buttons, door sensors, and emergency lowering mechanisms

Reliability: Hydraulic lifts are known for their reliability and durability, requiring minimal maintenance when properly installed and serviced.

Load Capacity: Hydraulic lifts are capable of handling heavy loads, making them suitable for freight and service elevators in addition to passenger elevators.

MRL LIFT

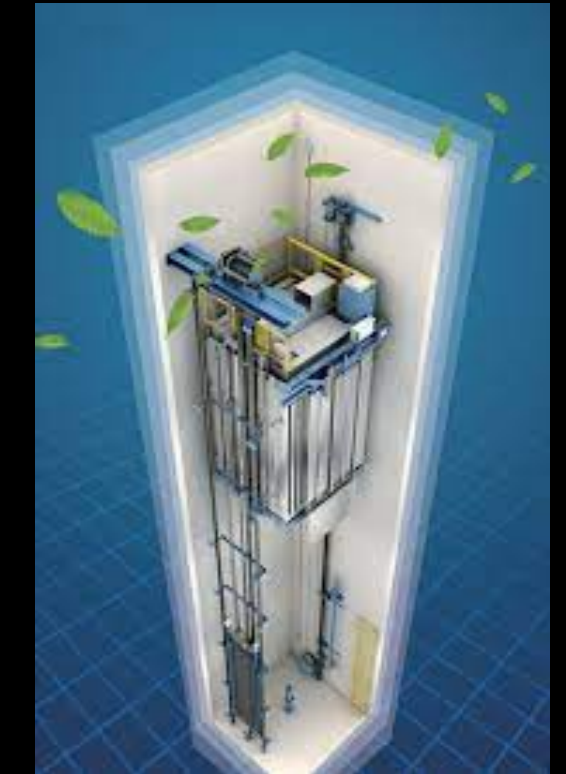
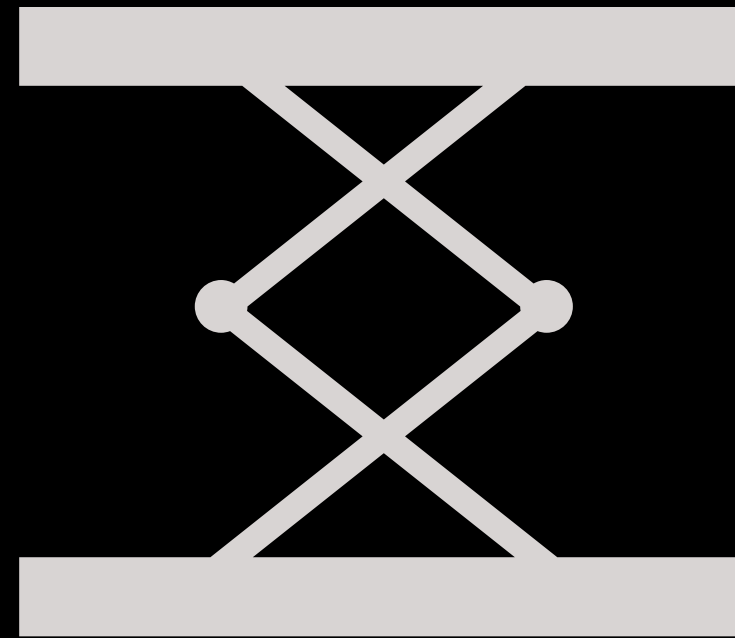

MRL stands for Machine Room-Less, referring to a type of elevator that does not require a separate machine room for housing the elevator machinery

It's important to consider specific requirements, building codes, and regulations when choosing the appropriate elevator type for a particular project.

MRL lifts are popular choice due to their space efficiency, energy savings, and design flexibility.

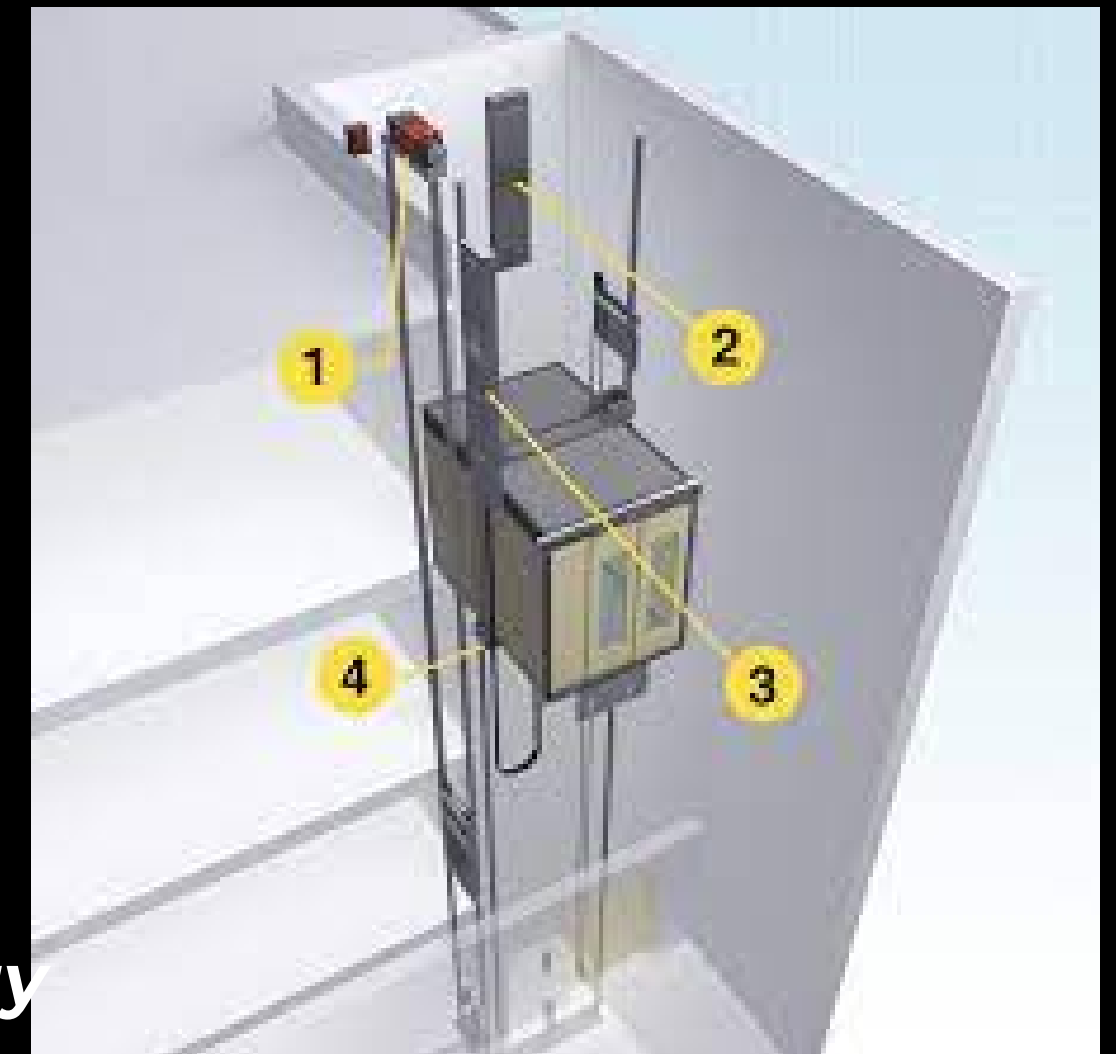

BENEFITS OF MRL LIFTS

Space Efficiency: MRL lifts are designed to maximize space utilization within a building. By eliminating the need for a separate machine room, more usable space is available for other purposes.

Design Flexibility: MRL lifts offer design flexibility, allowing architects and designers to have more freedom in incorporating elevators into the building layout. The absence of a machine room enables greater flexibility in elevator placement and configuration.

Reduced Construction Costs: MRL lifts can contribute to cost savings during construction, as the elimination of a machine room simplifies the installation process and reduces construction time and materials required.

Safety Features: MRL lifts incorporate various safety features, including emergency stop buttons, door sensors, and backup power systems, ensuring passenger safety in case of emergencies or power outages.

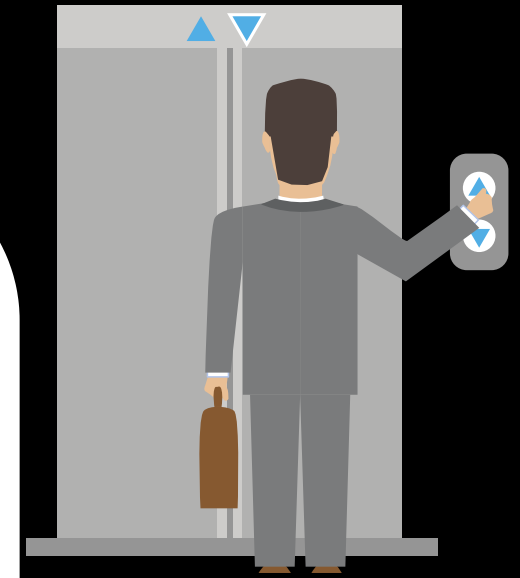

WHEEL CHAIR LIFT

Wheelchairs can be too bulky to fit into small areas and difficult to get over any incline. Wheelchair lifts help solve this problem. Wheelchair lift devices provide a surface for the rider that lifts into a vehicle so they can go where they need to.



STEEL STRUCTURE

A steel structure is a common choice for elevator construction due to its strength, durability, and ability to support heavy loads. Elevator systems consist of several components, and the steel structure plays a crucial role in providing the framework and support for the elevator shaft and its associated components

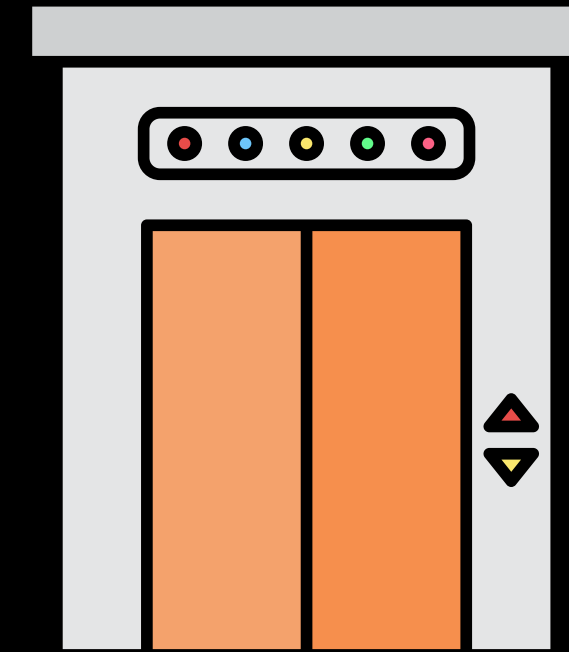

CIVIL STRUCTURE

The civil structure for an elevator primarily refers to the construction of the elevator shaft and the related components within the building. It involves the planning, design, and construction of the space where the elevator will be installed

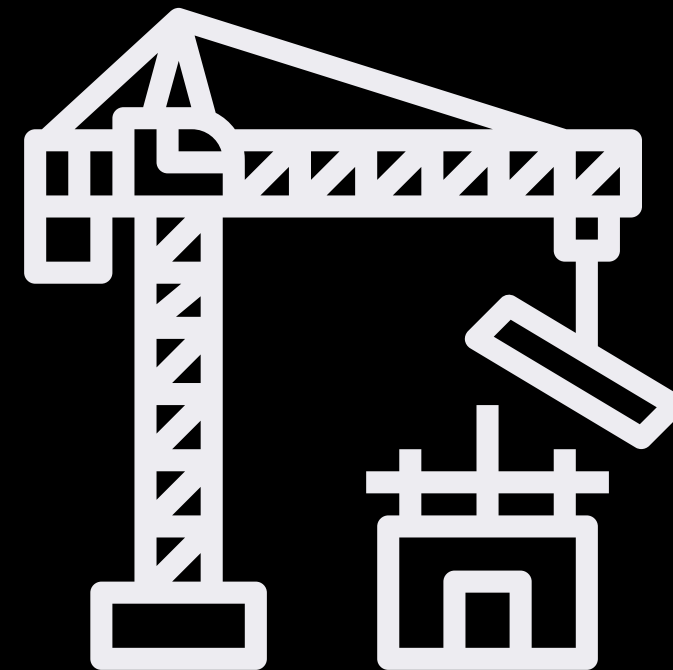

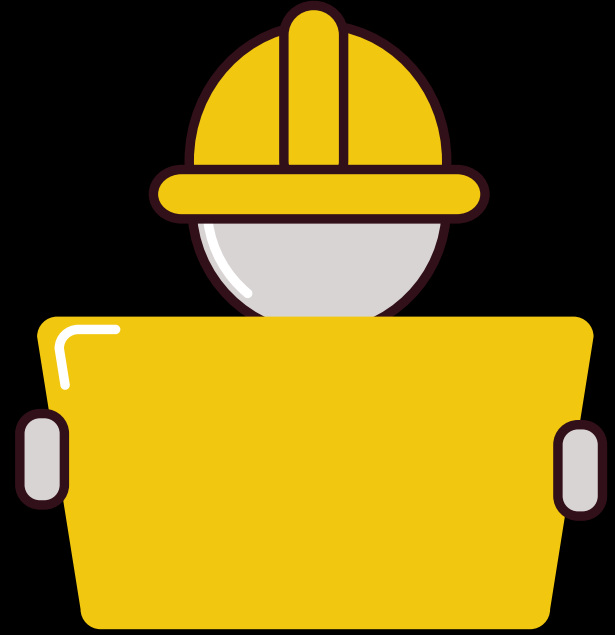

DESIGNS

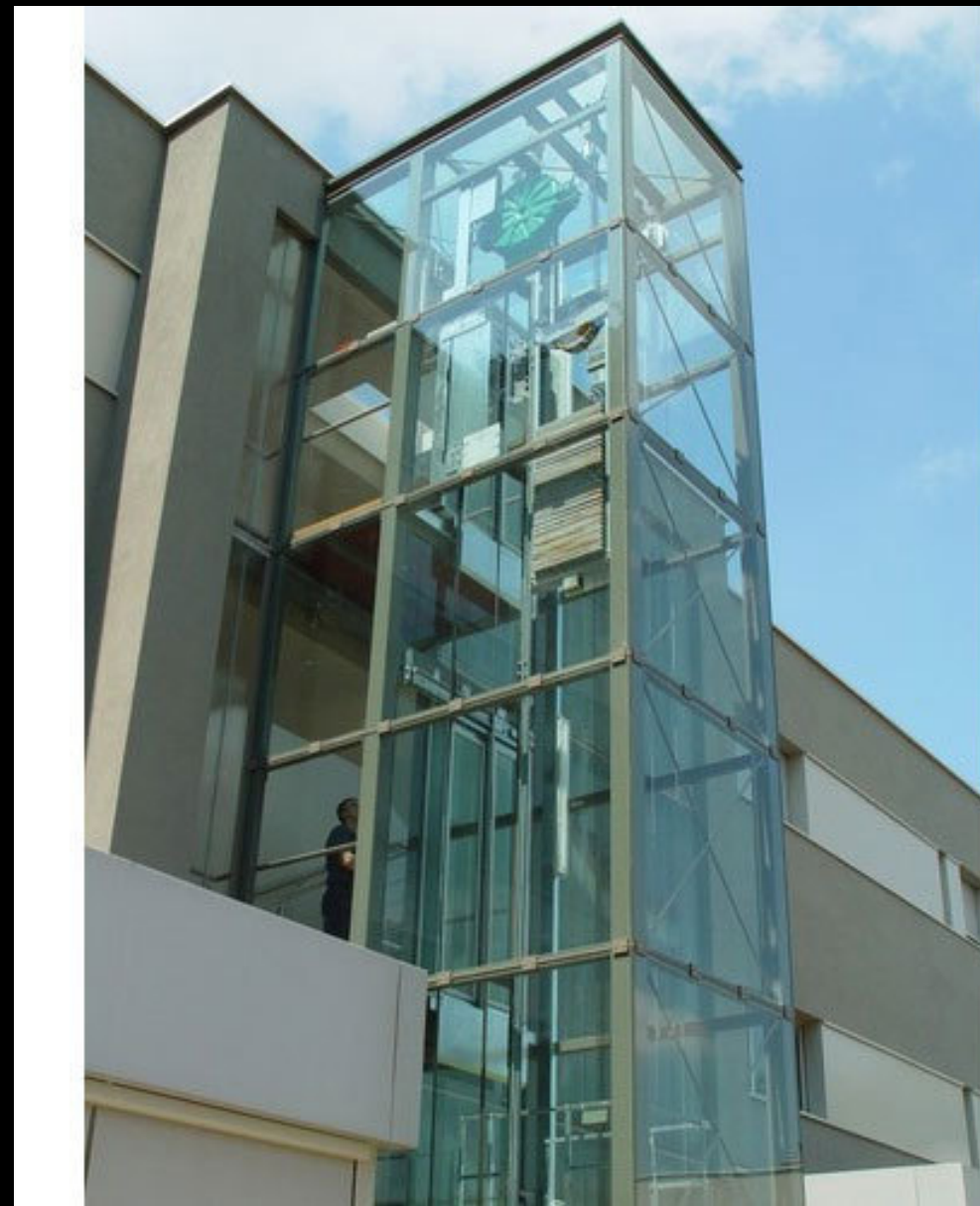



DESIGNS



OUR SERVICES



- ***Consultation and Feasibility Check***
- ***Local Authority Permissions***
- ***Installation of Lift***
- ***Annual Maintenance of Any Brand Lifts of Any Size***



CIVIL WORK



1. ***Making Shaft***
2. ***Lift Pit***
3. ***Platform***
4. ***Staircase***
5. ***Tiles Work***
6. ***Pit Digging***

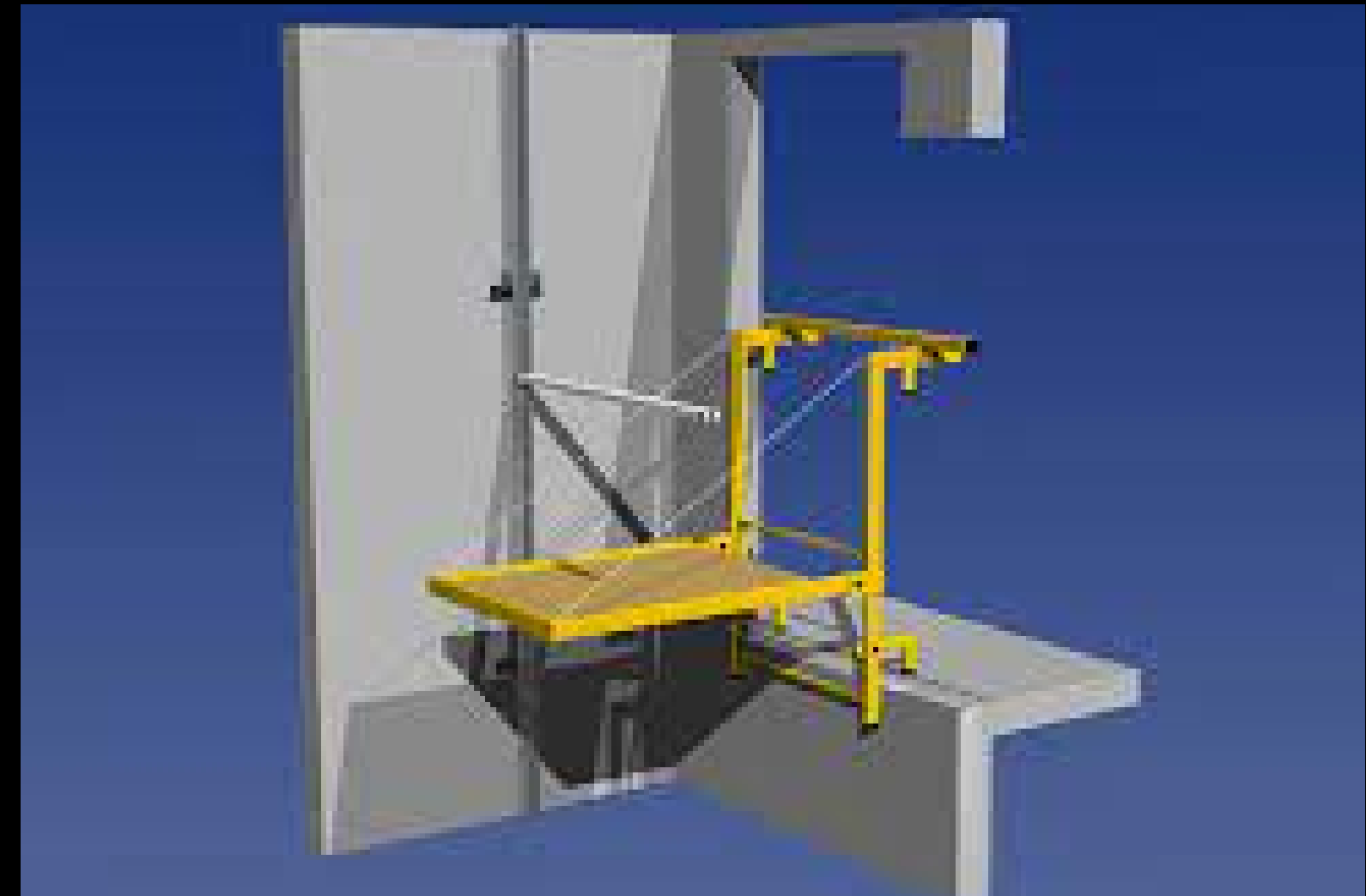

OTHER PRODUCTS

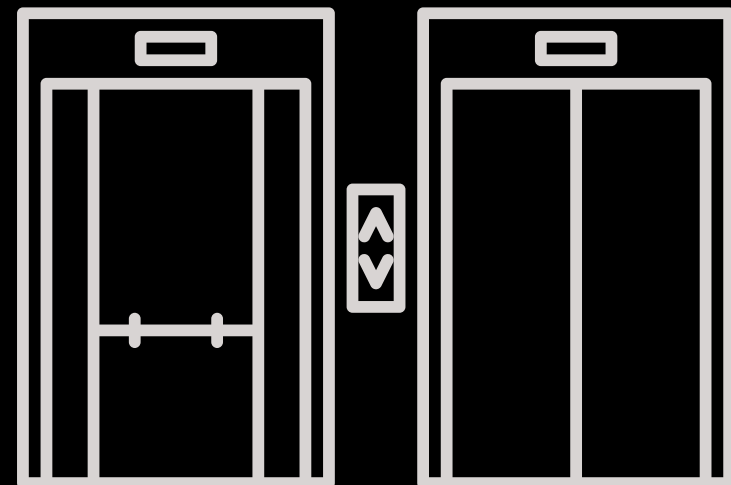

LIFT FOR HOUSE



OTHER PRODUCTS



***BHAVYA TECH INTERNATIONAL has installed
50+
elevators and currently services
30+ lifts to the
present. We have never given our
customers a chance to complain,
and all of our customers are
satisfied with our service. We are
growing rapidly in this industry.
You can search for us on Google***

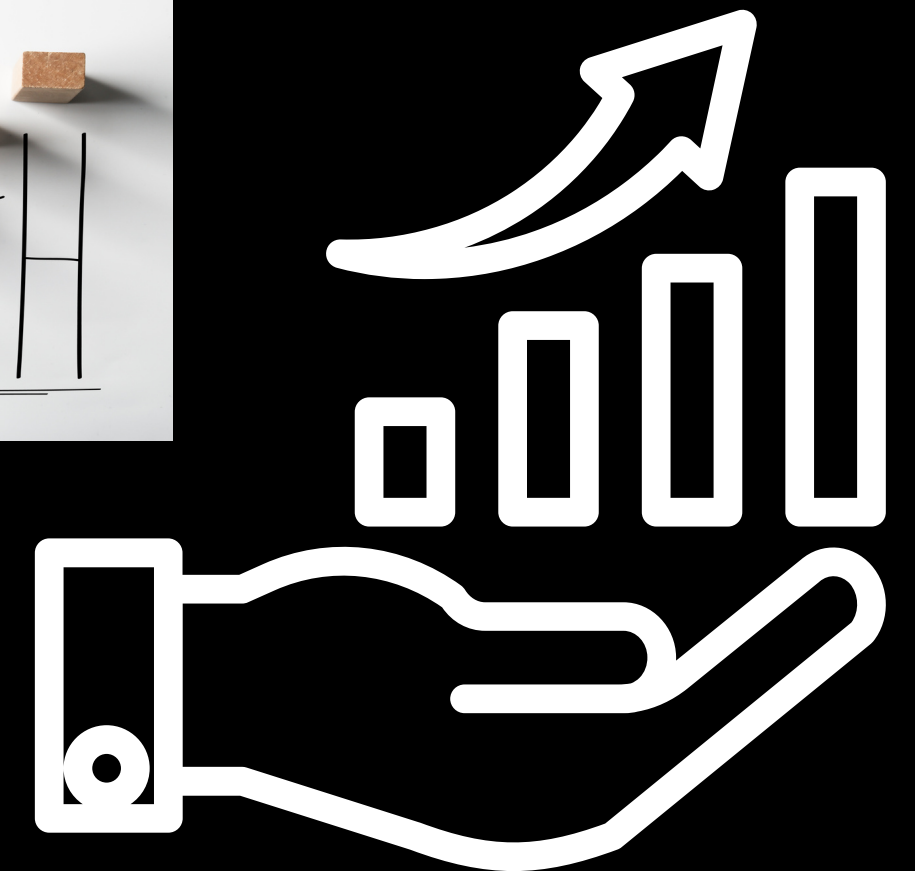

OUR TEAM

Mrs. BABLI SHARMA
(PROPRIETOR)

Mr. MUKESH SHARMA
(SALES MANAGER)

Mrs. BHAWANA SHARMA
(BACK OFFICE COORDINATOR)

Mr. PUSHPENDER
(PRODUCTION HEAD)

Mr. SHARAD SHARMA
(SALES COORDINATOR)

Mr. HARENDER
(FIELD OFFICER)



OUR LIFTS

LIFT FOR HOUSE



SS HYD. PASSNGER LIFT

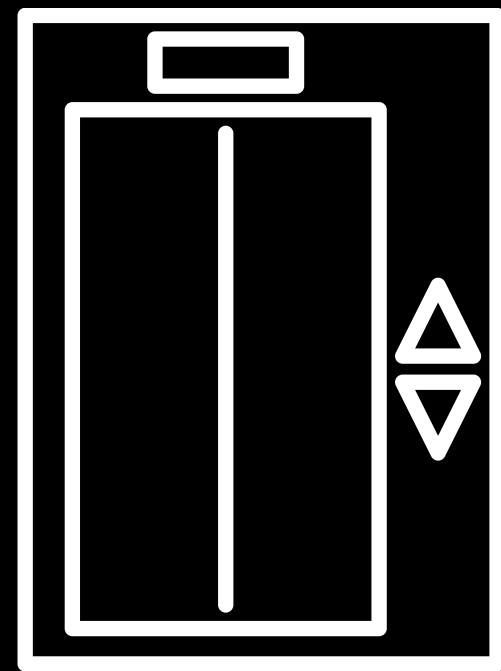
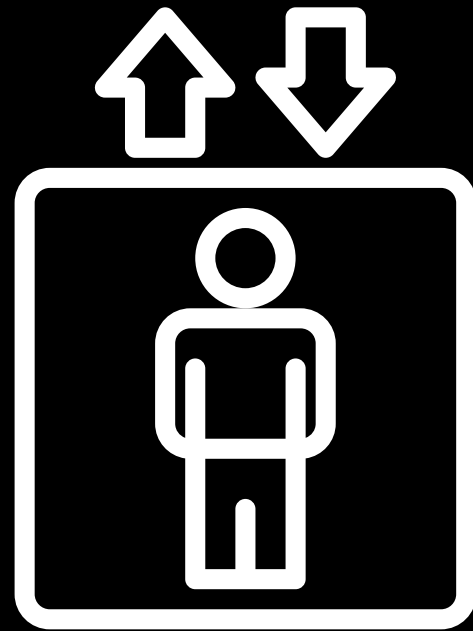

KITCHEN DUMBWAITER LIFT

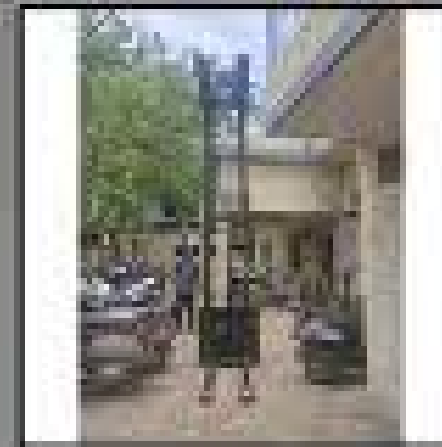

MILD-STEEL WALL MOUNTED LIFT

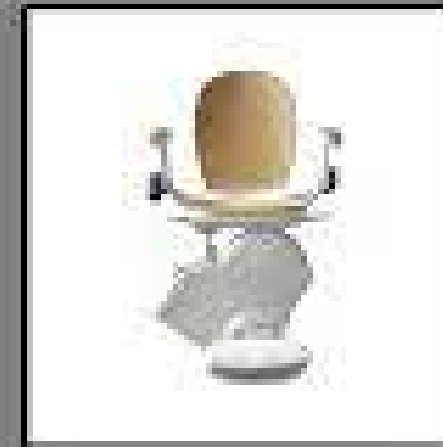

SUPERGLIDE STRAIGHT STAIRLIFT



HYDRAULIC HOME ELEVATOR



BTI Material Handling & Storage Systems

BHAVYA TECH INTERNATIONAL

BTI PASSENGER, GOODS, STAIR LIFT, HOME LIFT & OTHER LIFTING EQUIPMENTS

BHAVYA TECH INTERNATIONAL

TALK TO US

9540600035,9990906248

Email ID: bhavya.tech.int@gmail.com

JOIN US

*Thank
you!*